

# ms



**isel**<sup>®</sup> France *Des composants aux Systèmes*

*BP 41 - ZAC de la prévôté - 4 rue des côtes d'Orval - F-78550 - HOUDAN  
tel: +33(0) 130 461 201 fax: +33(0) 130 596 932 email: info@isel.fr*

## SYSTEMS

CNC machines..... E 2  
with step motor or servomotor drive

Accessories..... E 18

Robotics..... E 32

## CNC machines

## Overview

CNC machines

E 4

ICP series



CNC machines

E 6

ICV series



CNC machine

E 8

EuroMod



CNC machine

E 10

FlatCom M



CNC machine

E 12

FlatCom L



CNC machine

E 14

FlatCom XL

Flatbed and  
portal units

E 16



# CNC machines

# Overview

## Accessories

E 18

## Spindle motors

E 19

- iSA 500 with manual tool change
- iSA 750 with manual tool change
- iSA 1500 with manual tool change
- iSA 900 with automatic tool change
- iSA 2200 with automatic tool change
- iSA 3600 with automatic tool change

UFM 500 / UFM 1050

## CoolMin tool cooling system

E 26

## Tool changing stations

E 27

## Frequency converter

E 28

- Length measuring key
- Motor leads
- Vacuum cleaning

## Clamping rings

E 29

## Tool housings

## Vacuum clamping plates

E 30

## ROBOTICS

E 32

- IWH F-1 wafer handling robots
- IWH F-2 wafer handling robots
- IWH F-3 wafer handling robots
- IWH F-5 vacuum robots
- Vacuum elevator
- Linear track
- End effectors
- Pre-aligners
- Controller and accessories



# CNC machine

with step motor drive

ICP



ICP 4030 with hood open

## Dimensioned drawings

		ICP 3020	ICP 4030
Width W	[mm]	610	780
Depth D	[mm]	650	850
Height H1	[mm]	715	810
Height H2	[mm]	670	770
Height H3	[mm]	1030	1203
Height H4	[mm]	1080	1250

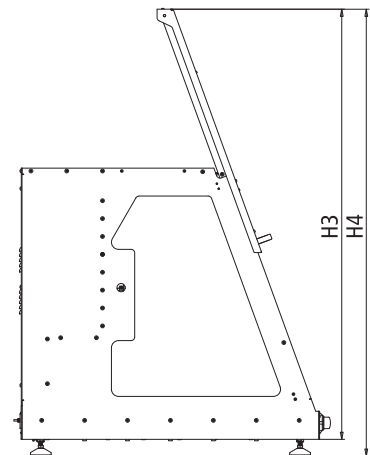
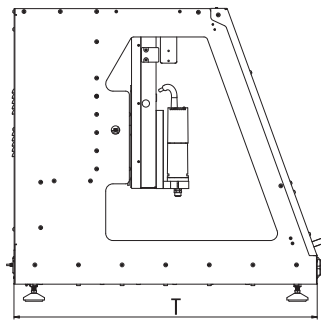
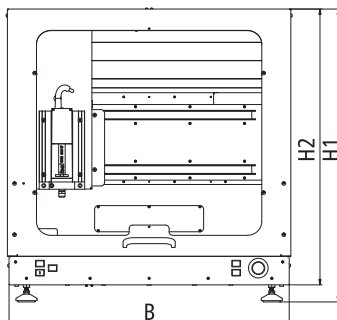

# CNC machine

## with step motor drive

# ICP

## General

CNC machines in the ICP series have been developed from the proven CPM series. By introducing a sliding door, the machines can now be operated in a sitting position which, *inter alia*, leads to shorter cycle times when opening the hood. The chassis is completely bolted instead of being welded like its predecessors. This produces higher precision when building the machine and makes servicing easier. In addition, it was possible to optimise the resonance and vibration behaviour and therefore lower noise build-up has been achieved.

## Technical specification

	ICP 3020	ICP 4030
Traverse path X/Y/Z [mm]	300 × 200 × 90	400 × 300 × 140
Clamping table surface W × D [mm]	500 × 250	600 × 375
Throughput [mm]	115	170
Dimensions W × D × H [mm]	610 × 650 × 715	780 × 850 × 810
Guides	Linear units with precision steel shafts and recirculating ball slots, clearance free adjustable	
Process speed X/Y/Z [mm/s]	100	
Repeatability [mm]	± 0.02	
Drive motors	Stepper motors	
Drive elements X/Y/Z	Ball screw drives 16 × 10/16 × 10/16 × 4 mm Clearance free adjustable (optional: 16 × 4 mm in X/Y/Z)	
Controller	iMC-P step controller with 4 final stages 48V/4.2A and 500W power supply unit with processor board	
Operation	Function keys and emergency shutdown	
Software	WinRemote (optional: ProNC, isy 2.5 PLUS)	
Weight [kg]	appr. 102	appr. 120
Part no.:	<b>280210 7406 *</b>	<b>280220 7405 *</b>

\* The deliverables include an accompanying pack with mechanical accessories (*inter alia* Hand lever clamping device, stop rails Triangle wrench, open jaw wrench, hook wrench, Allen key, one 6-socket bench extension, connection lead, power lead)

## Accessories

<b>280220 9012</b>	Cooling/spray device for ICP 3020/4030
<b>280120 9010</b>	Length measuring probe for ICP 3020/4030
<b>280120 9004</b>	Workspace lighting for ICP 3020/4030
<b>420003 0500</b>	Milling motor UFM 500, 500 W, 11,000...25,000 r.p.m.
<b>280110 9001</b>	Suction device for UFM 500
<b>Z13-337030</b>	isy-CAM 2.5 PLUS
<b>Z11-333500</b>	ProNC software
<b>310704 1631</b>	iSA 500 spindle motor up to 30,000 rpm, 500 W, with frequency converter, CoolMin tool cooling system, ER 11 clamping ring and motor lead
<b>310707 1631</b>	iSA 750 spindle motor up to 24,000 rpm, 750 W, with frequency converter, CoolMin tool cooling system, ER 16 clamping ring and motor lead (only ICP 4030)
<b>280210 9001</b>	Suction device for iSA 750
<b>280000 0046</b>	Fixing plate for main spindle drive
<b>290055</b>	Vice 1 (W 130 × H 45 × L 152 mm)
<b>290056</b>	Vice 2 (W 180 × H 75 × L 215 mm)

# CNC machine

with servomotor drive

## ICV 4030

**Control unit**  
... with integrated  
control computer.



ICV 4030 with hood open

### Dimensioned drawings

		ICV 4030
Width W	[mm]	780
Depth D	[mm]	835
Height H1	[mm]	806
Height H2	[mm]	765
Height H3	[mm]	1203
Height H4	[mm]	1250

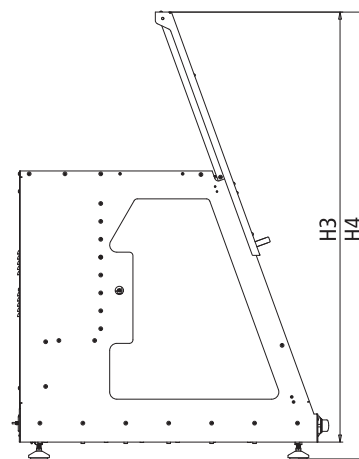
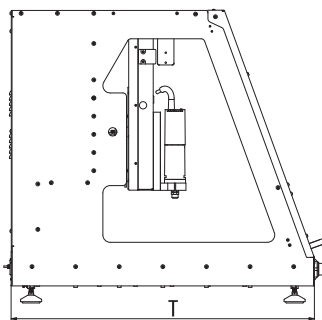
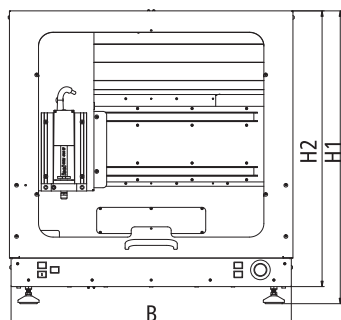

# CNC machine

## with servomotor drive

# ICV 4030

## General note

The ICV 4030 has been developed from the proven, 3D-enabled CNC machine CPV 4030, which is delivered ready for connection to the mains.

The sliding hood, opening upwards, can be operated conveniently from a sitting position. The completely bolted chassis produces higher precision when building the machine and is easier to service. In addition, it was possible to optimise the resonance and vibration behaviour and therefore lower noise build-up has been achieved. Prerequisites for working with the ICV 4030 are simply basic knowledge of CNC systems, general IT literacy and basic knowledge of graphics programs!

## Technical specification

	ICV 4030
Traverse path X/Y/Z [mm]	395 x 300 x 100
Clamping table surface W × D [mm]	600 x 375
Throughput [mm]	150
Dimensions W × D × H [mm]	780 x 835 x 806
Guides	Linear units with precision steel shafts and recirculating ball slots, adjustable for no play
Processing speed X/Y/Z [mm/s]	200
Repeatability [mm]	± 0,02
Drive motors	Servomotors
Drive elements X/Y/Z	Recirculating ball transmission 16 × 10/16 × 10/16 × 10 mm clearance free adjustable (optional: 16 × 4 mm in X/Y/Z)
Controller	iMC CAN controller with 3 drive controllers, integrated control computer, I/O module, safety circuit and rest state monitoring Power supply unit 48V/1000 W
Operation	Function keys and emergency shutdown
Software	WinRemote (optional: ProNC, isy 2.5 PLUS)
Weight [kg]	appr. 120
Part no.	<b>280230 4405 *</b>

\* The deliverables include an accompanying pack with mechanical accessories (*inter alia* Hand lever clamping device, stop rails, triangle wrench, open jaw wrench, hook wrench, Allen key, one 6-socket bench extension, connection lead, power lead)

## Accessories

<b>280220 9012</b>	Cooling/spray device for ICV 4030
<b>280120 9010</b>	Length measurement probe for ICV 4030
<b>280120 9004</b>	Workspace lighting for ICV 4030
<b>420003 0500</b>	Milling motor 500 W, 11,000...25,000 r.p.m.
<b>420003 1050</b>	Milling motor 1050 W, 11,000...25,000 r.p.m.
<b>280110 9001</b>	Suction device for UFM 500/1050
<b>280120 9003</b>	Engraving mat, incl. adapter plate
<b>Z13-337030</b>	isy-CAM 2.5 Plus
<b>Z11-333500</b>	ProNC Software
<b>310704 1631</b>	iSA 500 spindle motor up to 30,000 rpm, 500 W, with frequency converter, CoolMin tool cooling system, ER 11 clamping ring and motor lead
<b>310707 1631</b>	iSA 750 spindle motor up to 24,000 rpm, 750 W, with frequency converter, CoolMin tool cooling system, ER 16 clamping ring and motor lead
<b>280210 9001</b>	Suction device for iSA 500/iSA 750
<b>280000 0046</b>	Fixing plate for main spindle drive

Note:

Vacuum clamping plates can be clamped in sizes A5 - A3. (see page E31)

# CNC machine

with servomotor drive

**EUROMOD<sup>®</sup>**

**EuroMod MP 30** with closed sliding door

## Technical specification

	<b>EUROMOD<sup>®</sup></b> MP 30	<b>EUROMOD<sup>®</sup></b> MP 45	<b>EUROMOD<sup>®</sup></b> MP 65
<b>Traverse path X/Y/Z [mm]</b>	650/300/250	650/450/250	1000/650/250
<b>Clamping table surface W×D [mm]</b>	900x350	900x500	1200x700
<b>Throughput [mm]</b>	350		
<b>Dimensions W × D × H [mm]</b>	1160x800x1700	1160x1110x1700	1480x1510x1700
<b>Processing speed X/Y/Z</b>	appr. 250 mm/s		
<b>Repeatability [mm]</b>	± 0,02		
<b>Drive motors</b>	48V servomotors		
<b>Drive elements X/Y/Z</b>	Recirculating ball drive, clearance free adjustable		
<b>Controller</b>	iMD CAN controller with 3 drive controllers, expandable to 12 axes (max. 6 interpolated & 6 handling axes), PC, I/O module, safety circuit with rest state monitoring, power supply unit 48V/1000 W		
<b>Operation</b>	19" CNC control panel with touch screen, keyboard and mouse		
<b>Weight [kg]</b>	appr. 250	appr. 280	appr. 375
<b>Software</b>	Windows, WinRemote (optional: ProNC, isy 2.5 PLUS)		
<b>Connection values</b>	230V, 16A		
<b>Part no.</b>	<b>275133 33665</b>	<b>275143 33665</b>	<b>275153 33665</b>

\* without mounted components on the axes.

# CNC machine

## with servomotor drive

**EUROMOD<sup>®</sup>**

### General note

The choice of the ideal CNC machine for you should focus both on the clamping area for the workpiece, materials or plates to be machined and on the strategy or difficulties of the machining. In principal, all machines are perfectly suited for machining light metals, non-ferrous metals, plastics and wood. Extensive range of accessories for all our CNC machines to order (see page E18 et seq.).

### Options

- PC control console with 2 free PCI plug-ins (for use by external PCI hardware)
- Stainless steel keyboard
- Safety light curtain
- Milling and engraving spindles
- SK11/SK20 automatic tool change stations
- Minimum quantity lubrication or CoolMin cooling system
- Vacuum clamping benches
- Suction device
- 4. Axis e. g. RDH series installation
- pneumatic sliding door
- closed hood attachment

### Setup

- Portal: fixed, bench: mobile

### Dimensioned drawings/dimensions

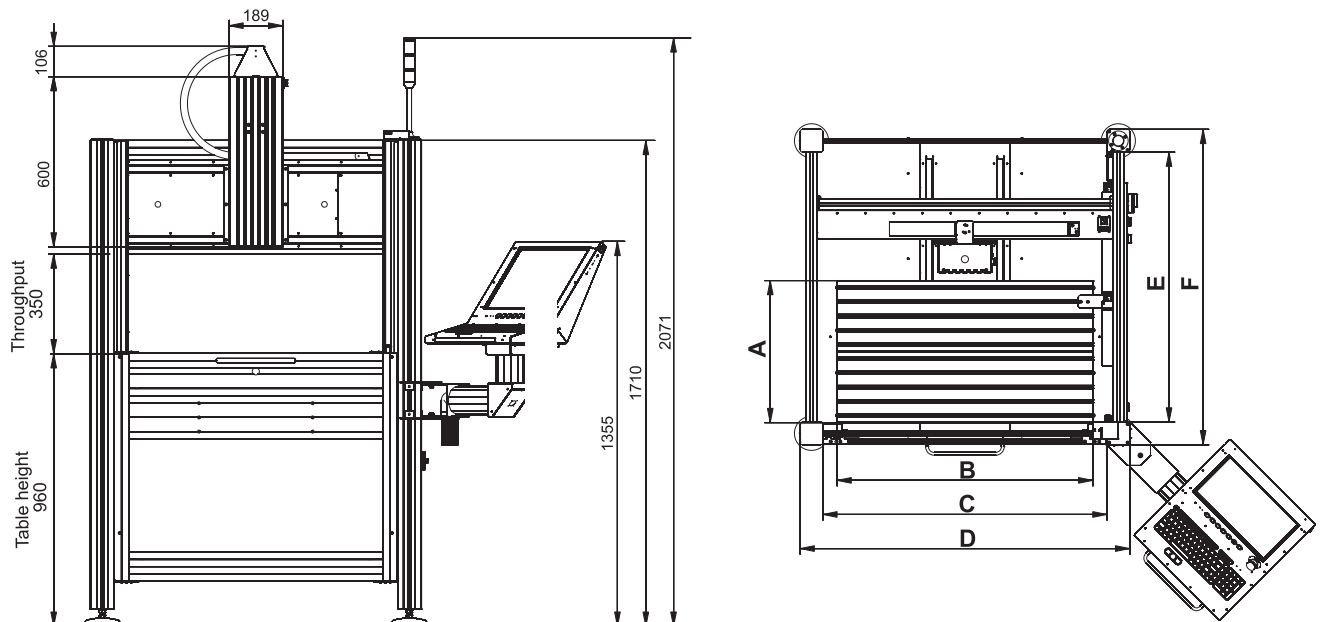

	A	B	C	D	E	F
<b>EuroMod MP30</b>	350	900	1000	1160	640	800
<b>EuroMod MP45</b>	500	900	1000	1160	950	1110
<b>EuroMod MP65</b>	700	1200	1200	1480	1350	1510

Technical specifications subject to change.

# CNC machine

with servomotor drive

**FLATCom<sup>®</sup>**  
M series



FlatCom M 30 without hood

FlatCom M 30 with hood open

## Technical specification

	<i>FLATCom<sup>®</sup></i> M 20	<i>FLATCom<sup>®</sup></i> M30	<i>FLATCom<sup>®</sup></i> M40	<i>FLATCom<sup>®</sup></i> M50
Traverse path X/Y/Z [mm]	700/600	700/900	1200/900	1200/1400
Z lift [mm]	150 (optional 250, in each case without processing unit)			
Clamping table surface W×D [mm]	750x750	750x1000	1250x1000	1250x1500
Z-Throughput [mm]	200 (optional 300, in each case without processing unit)			
Dimensions W × D × H [mm]	1420x1150x1870	1420x1450x1870	1920x1450x1870	1920x1950x1870
Processing speed X/Y/Z	appr. 250 mm/s			
Repeatable accuracy [mm]	± 0,02			
Drive motors	48V servomotors			
Drive elements X/Y/Z	Recirculating ball drive, clearance free adjustable			
Controller	iMD CAN controller with 3 drive controllers, expandable to 12 axes (max. 6 interpolated & 6 handling axes), PC, I/O module, safety circuit with rest state monitoring, power supply unit 48V/1000 W			
Operation	19" CNC control panel with touch screen, keyboard and mouse			
Weight [kg]	appr. 300	appr. 340	appr. 450	appr. 525
Software	Windows, WinRemote (optional: ProNC, isy 2.5 PLUS)			
Connection values	400V, 16A			
Part no.	<b>275023 32355 **</b>	<b>275033 32355 **</b>	<b>275043 32355 **</b>	<b>275053 32355 **</b>

\* without mounted components on the axes.

\*\* with switchgear cabinet and table

# CNC machine

## with servomotor drive

**FLATCom**<sup>®</sup>  
M series

### General note

The choice of the ideal CNC machine for you should focus both on the clamping area for the workpiece, materials or plates to be machined and on the strategy or difficulties of the machining. In principal, all machines are perfectly suited to machining **light metals, non-ferrous metals, plastics and wood**. Extensive range of accessories for all our CNC machines to order (see page E18 *et seq.*).

### Options

- PC control console with 2 free PCI plug-ins (for use by external PCI hardware)
- Safety light curtain
- toothed belt drive
- Milling and engraving spindles
- SK11/SK20 automatic tool change stations
- Minimum amount lubrication or CoolMin cooling system
- Vacuum clamping benches
- Suction device
- 4. Axis e. g. RDH series installation
- Version without hood
- Maximum 6 interpolated axes + 6 handling axes
- Portal gap 300 mm
- pneumatic sliding door
- closed hood attachment

### Setup

- Portal: mobile, bench: fixed

### Dimensioned drawings/dimensions

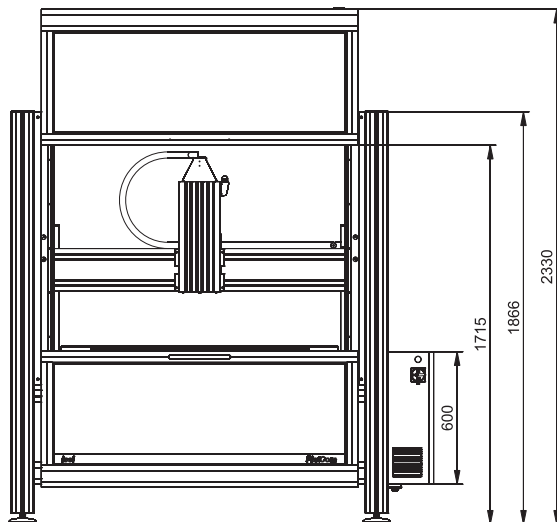

FlatCom with sub-frame and hood

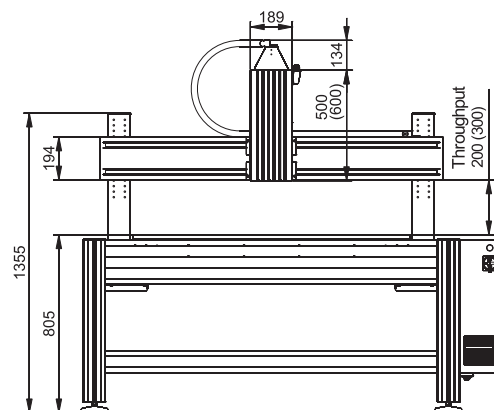

FlatCom with sub-frame, without hood

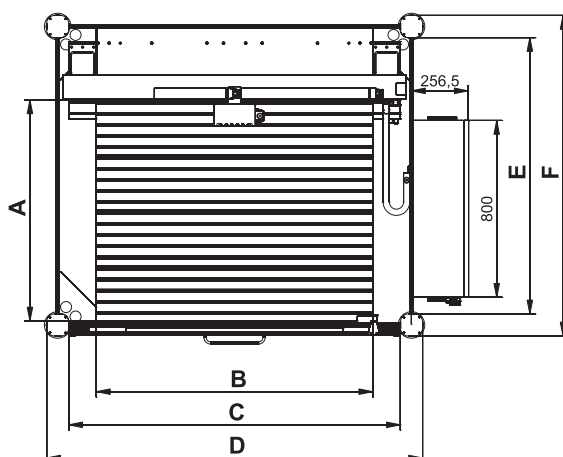

	A	B	C	D	E	F
FlatCom M20	750	750	1000	1200	950	1150
FlatCom M30	1000	750	1000	1200	1250	1450
FlatCom M40	1000	1250	1500	1700	1250	1450
FlatCom M50	1500	1250	1500	1700	1750	1950

# CNC machine

with servomotor drive

**FLATCom**<sup>®</sup>  
L series



FlatCom L without hood

## Technical specification

	<b>FLATCom</b> <sup>®</sup> L150	<b>FLATCom</b> <sup>®</sup> L250	<b>FLATCom</b> <sup>®</sup> L300
Processing areas X/Y/Z [mm] *	1500/1700	2500/1700	1700/3000
Z lift [mm]	200 (optional 300, in each case without processing unit)		
Clamping table surface W × D [mm]	1750 × 2250	2750 × 2250	2250 × 3250
Z-Throughput [mm]	250 (optional 500, in each case without processing unit)		
Dimensions W × D × H [mm]	2216 × 2430 × 1600	3216 × 2430 × 1600	2430 × 3716 × 1600
Processing speed X/Y/Z	appr. 250 mm/s		
Repeatable accuracy [mm]	± 0,02		
Drive motors	48 V servomotors		
Drive elements X/Y/Z	Recirculating ball drive, clearance free adjustable		
Controller	iMD CAN controller with 3 drive controllers, expandable to 12 axes (max. 6 interpolated & 6 handling axes), PC, I/O module, safety circuit with rest state monitoring, power supply unit 48 V/1000 W		
Operation	19" CNC control panel with touchscreen, keyboard and mouse		
Weight [kg]	appr. 435	appr. 510	appr. 580
Software	Windows, WinRemote (optional: ProNC, isy 2.5 PLUS)		
Connection values	400 V, 16 A		
Part no.	<b>275062 34565</b> **	<b>275072 34565</b> **	<b>275082 34565</b> **

\* without mounted components on the axes.

\*\* without protective hood

# CNC machine

## with servomotor drive

**FLATCom<sup>®</sup>**  
L series

### General note

The choice of the ideal CNC machine for you should focus both on the clamping area for the workpiece, materials or plates to be machined and on the strategy or difficulties of the machining. In principal, all machines are perfectly suited to machining **light metals, non-ferrous metals, plastics and wood**. Extensive range of accessories for all our CNC machines to order (see page E18 *et seq.*).

### Options

- PC control console with 2 free PCI plug-ins (for use by external PCI hardware)
- Safety light curtain
- toothed belt drive
- Milling and engraving spindles
- SK11/SK20 automatic tool change stations
- Minimum quantity lubrication or CoolMin cooling system
- Vacuum clamping benches
- Suction device
- 4. Axis e. g. RDH series installation
- Version without hood
- Maximum 6 interpolated axes + 6 handling axes
- Portal gap 300 mm
- Protective hood

### Setup

- Portal: mobile, bench: fixed

### Dimensioned drawings/dimensions

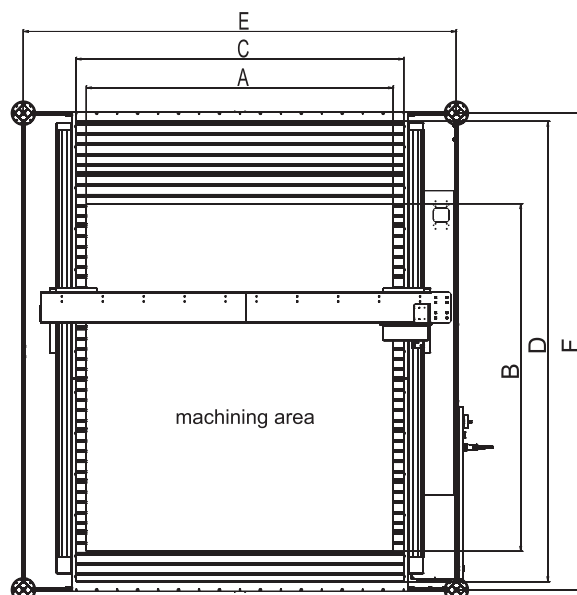
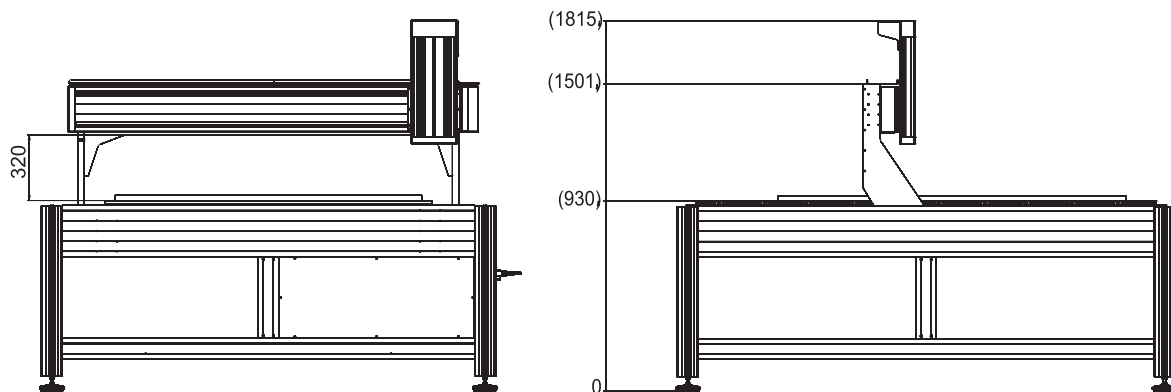

	A	B	C	D	E	F
<b>FlatCom L 150</b>	1500	1700	1750	2000	2116	2330
<b>FlatCom L 250</b>	2000	1700	1750	2000	2616	2330
<b>FlatCom L 300</b>	2000	3000	2050	3250	2616	2616

# CNC machine

with servomotor drive

**FLATCom®**  
XL series



FlatCom XL with control panel

## Technical specification

	FLATCom® 102/72	FLATCom® 102/112	FLATCom® 142/112	FLATCom® 142/162	FLATCom® 142/252
Processing areas X/Y/Z [mm] *	1020/720/220	1020/1120/220	1420/1120/220	1420/1620/220	1420/2520/220
Clamping table surface W×D [mm]	1125 x 1300	1125 x 1700	1500 x 1700	1500 x 2200	1500 x 3050
Z-Throughput [mm]	235 (optional 435, in each case without processing unit)				
Dimensions W × D × H [mm]	2084/1584/1890	2084/1984/1890	2459/1984/1890	2459/2484/1890	2459/3384/1890
Processing speed X/Y/Z	appr. 250				
Repeatable accuracy [mm]	± 0,02				
Drive motors	48V servomotors				
Drive elements X/Y/Z	Recirculating ball drive, clearance free adjustable				
Controller	iMD CAN controller with 3 drive controllers, expandable to 12 axes (max. 6 interpolated & 6 handling axes), PC, I/O module, safety circuit with rest state monitoring, power supply unit 48V/1000 W				
Operation	19" CNC control panel with touchscreen, keyboard and mouse				
Weight [kg]	appr. 550	appr. 600	appr. 700	appr. 800	appr. 1000
Software	Windows, WinRemote (optional: ProNC, isy CAD-CAM)				
Connection values	400 V, 16 A				
Part no.	274552 0013	274553 0013	274554 0013	274555 0013	274556 0013

\* without mounted components on the axes.

# CNC machine

## with servomotor drive

**FLATCom<sup>®</sup>**  
XL series

### General note

The choice of the ideal CNC machine for you should focus both on the clamping area for the workpiece, materials or plates to be machined and on the strategy or difficulties of the machining. In principal, all machines are perfectly suited to machining **light metals, non-ferrous metals, plastics and wood**. Extensive range of accessories for all our CNC machines to order. (see page E18 *et seq.*)

### Options

- PC control console with 2 free PCI plug-ins (for use by external PCI hardware)
- Safety light curtain
- toothed belt drive
- Milling and engraving spindles
- SK11/SK20 automatic tool change stations
- Minimum quantity lubrication or CoolMin cooling system
- Vacuum clamping benches
- Suction device
- 4. Axis e. g. RDH series installation
- Version without hood
- Maximum 6 interpolated axes + 6 handling axes
- Portal gap 300 mm
- closed hood attachment

### Setup

- Portal: mobile, bench: fixed

### Dimensioned drawings/dimensions

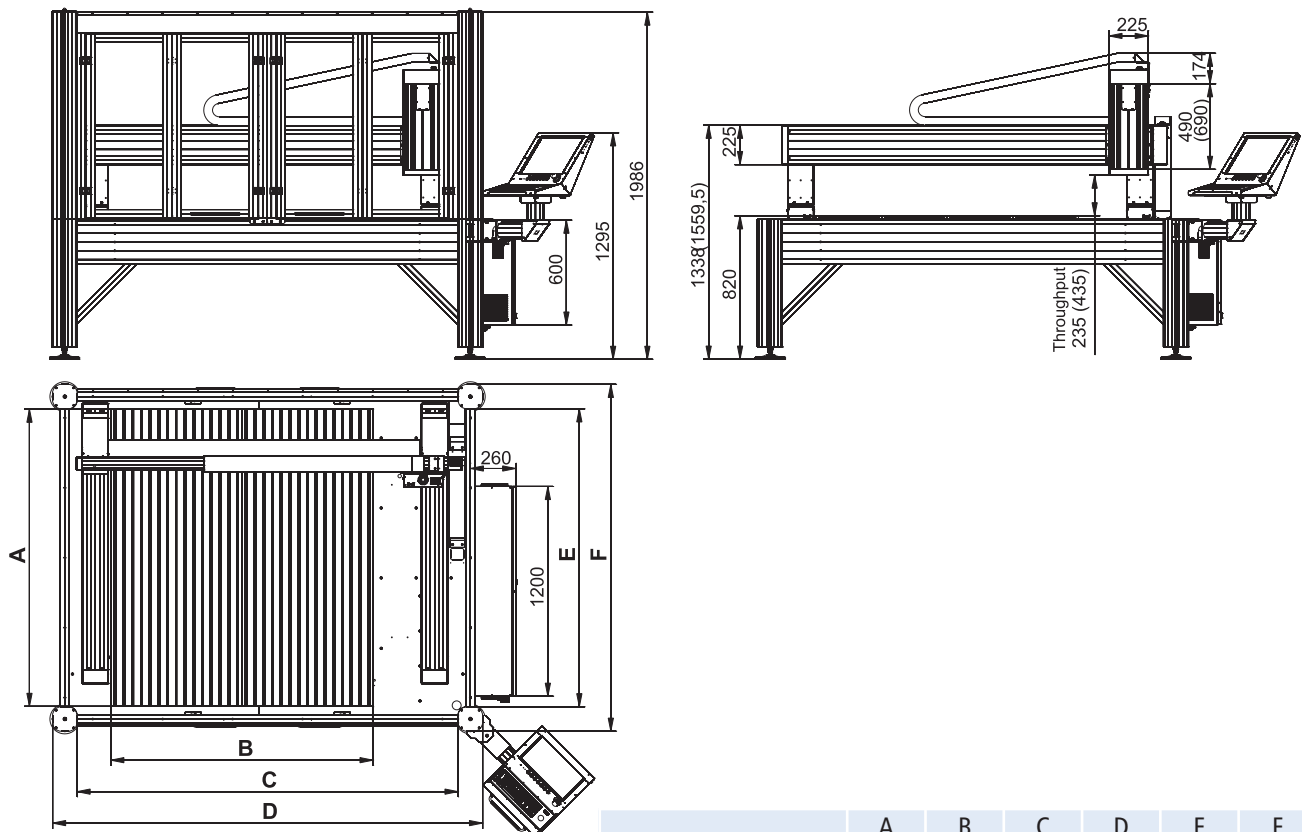

	A	B	C	D	E	F
FlatCom XL 102/72	1300	1125	1804	2084	1304	1584
FlatCom XL 102/112	1700	1125	1804	2084	1704	1984
FlatCom XL 142/112	1700	1500	2179	2459	1704	1984
FlatCom XL 142/162	2200	1500	2179	2459	2204	2484
FlatCom XL 142/252	3050	1500	2179	2459	3100	3380

# Flatbed and portal units



**Flat bed unit** with Z axis



**Portal unit** with Z axis

## General note

Flatbed units as defined in the machine guideline are incomplete machines according to the modular system with processing paths of 250 to 1250 mm. Step motors (MS200HT), set for no-play, are used as spindle drives. Recirculating ball drives with a repeatability of  $\pm 0.02$  mm (positioning reproducibility) are used.

The linear guides used are the isel double track feeds, proven over many years, with no-play pre-stressed linear ball bearings and recirculating ball spindles with a repeatability of  $\pm 0.02$  mm.

All units are equipped with two limit switches per spindle.

The machining and positioning units are available in a number of versions and are characterised by smooth running and high process speeds. The use of high quality aluminium components with flat-milled surfaces achieves low weight and high accuracy.

isel X/Y/Z units are the ideal basis for setting up machines and systems for fitting and assembling, pressing and engraving, drilling and milling, milling and screwing, shaping and modelling, bonding and casting, soldering and welding, measuring and checking, sawing and cutting, etc..

## Dimensioned drawings

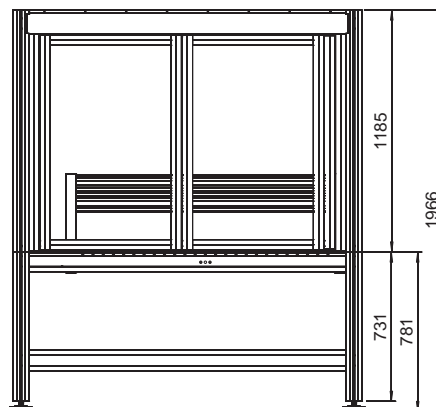
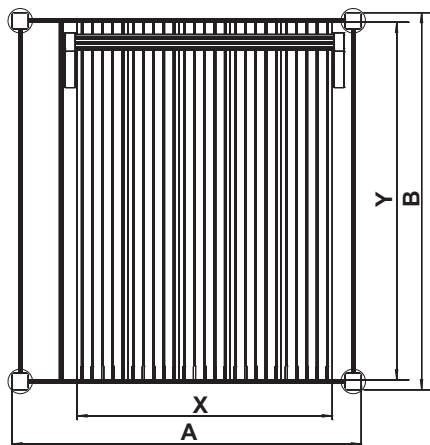
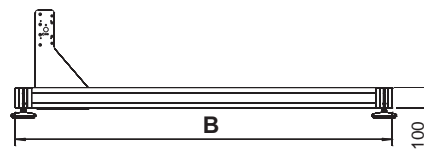
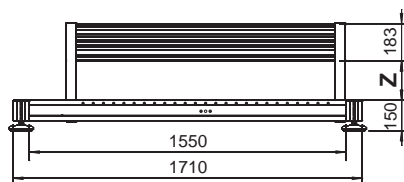

# Flatbed and portal units

## X/Y flatbed units FB2

Part no.	Chassis A × B (mm)	Clamping surface X × Y (mm)	Process path (mm)	Z-Through- put (mm)
<b>246203</b>	1210 x 946	750 x 850	500 x 530	190
<b>246203 2040</b>	1210 x 1196	750 x 1100	750 x 530	
<b>246203 2054</b>	1210 x 1446	750 x 1350	1000 x 530	
<b>246203 2067</b>	1460 x 1446	1000 x 1350	850 x 780	
<b>246203 2130</b>	1710 x 1846	1250 x 1750	1250 x 1030	

All flatbed units are fitted with **16 × 4 mm recirculating ball drives** as standard



## Z axes for flatbed units

Part no.	Lift (mm)	
<b>230514</b>	75	with 24V magnetic brake
<b>230514 0400</b>	160	with 24V magnetic brake

## Sub-frames

Part no.	suitable for flatbed unit with clamping area:
<b>248500 0027</b>	850 x 750
<b>248500 0040</b>	1100 x 750
<b>248500 0054</b>	1350 x 750
<b>248500 0067</b>	1350 x 1000
<b>248500 0130</b>	1750 x 1250

## Portal units PA2

Part no.	Part no. (without motor)	Process path (mm)	Ball screw drive (mm)	Lift (mm)
<b>242 402</b>	<b>242 409</b>	280 x 490	16 x 4	75
<b>243 402</b>	<b>243 409</b>	280 x 490	16 x 4	without Z axis

## Software

Part no.	
Z11 - 333 500 Z13 - 337 030	ProNC software for CAN-CNC controllers isy-CAM 2.5 Plus (only available in combination with a unit)

## Options

- matched controller (e.g.: iMC-S8)
- Software modules for operation in CAM, CNC, and PLC applications
- Sub-frame
- Enclosure
- Spindle motors (see E18 *et seq.*)

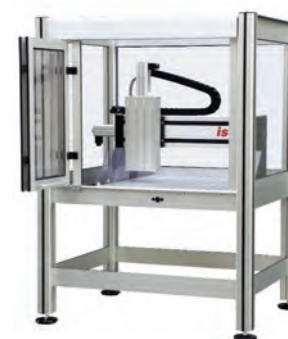

## Enclosures

Part no.	suitable for flatbed unit with clamping area:
<b>248200 0000</b>	850 x 750
<b>248200 2040</b>	1100 x 750
<b>248200 2054</b>	1350 x 750
<b>248200 2067</b>	1350 x 1000
<b>248200 2130</b>	1750 x 1250