

## Rotation units

## Overview

RDH-M Indexing table / Rotary unit

C 104



RDH-S Indexing table / Rotary unit

C 106



RDH-XS Indexing table / Rotary unit

C 108



DSH-S Rotary / swivel unit

C 110



RF 1 Indexing table

C 112



**isel**<sup>®</sup> France Des composants aux Systèmes

BP 41 - ZAC de la prévôté - 4 rue des côtes d'Orval - F-78550 - HOUDAN  
tel: +33(0) 130 461 201 fax: +33(0) 130 596 932 email: info@isel.fr

## Rotation units

## Overview

iZD 54 Rotary unit

C 114



MD 1 Miniature rotary unit

C 116



ZD 30 Rotary unit

C 118

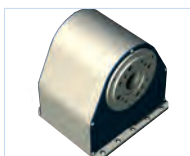

ZR 20 Indexing table

C 120



ZDS 2030

C 121



Pin assignments

C 122

Transported loads

C 123

Machining forces

Feed

CAD data on our website [www.isel.com](http://www.isel.com)

## Indexing table / Rotary unit

## RDH-M



RDH-M as indexing table  
(solid shaft design)

RDH-M as rotary unit  
(hollow shaft design)



## Features

- With precision transmission
  - High load capacity, rigid drive bearing
  - Absence of play and high torsional rigidity
- Reduction 1:51 or 1:101
- Stepper or servomotor
- Protection class IP 65
- Stainless design
- Transfer accuracy < 1 minute of arc
- Repeatability <  $\pm 6$  seconds of arc
- Available in solid or hollow shaft design
- No maintenance

For pin assignment see page C122  
For transport loads see page C123

## Ordering key

2 6 6 2 X X 0 X 0 0

## Flanged shaft

0 = solid shaft  
1 = hollow shaft

## Transmission reduction

0 = 101  
1 = 51

## Motors

0 = Stepper motor MS 200 HAT with encoder (400 imp., 3-channel, RS422)  
3 = brushless EC servomotor EC 60S  
4 = brushed DC servomotor DC 100  
5 = Stepper motor without encoder

## Accessories



## Chuck assembly

3-jaw chuck  $\varnothing$  125  
Part no.: **269062 0125**

4-jaw chuck  $\varnothing$  125  
Part no.: **269061 0125\***

\*including flange



## Aluminium T-key plate

$\varnothing$  240 mm/PT 25  
Part no.: **269050 0240**

$\varnothing$  365 mm/PT 25  
Part no.: **269050 0365**



## Aluminium rotary plate

$\varnothing$  490 mm, customised  
fixing borings available at extra cost

Part no.: **269051 0500**



## Tailstock unit RE M

Part no.: **269100 2100**  
(1000 mm)  
Part no.: **269100 2150**  
(1500 mm)  
Part no.: **269100 2200**  
(2000 mm)

# Indexing table / Rotary unit

# RDH-M

## Technical specification

	Stepper motor MS 200 HT *		EC servomotor EC 60S (brushless)		DC servomotor DC 100 (brushed)	
Reduction ratio	1:51	1:101	1:51	1:101	1:51	1:101
Nominal speed [1/min]	4	2	22	11	22	11
	at 1500 Hz (225 1/min)		at 1100 1/min			
Max. speed [1/min]	24	12	59	30	59	30
	at 8000 Hz		--			
Nominal torque [Nm]	24	46	9	17	7	14
	bei 1500 Hz		--			
Max. torque (short term) [Nm]	--	--	42	80	39	73
Nominal holding torque (static load) [Nm]	55	108	26	51	15	30
Max. Transmission load [Nm]	98	157	98	157	98	157
	Limit for repeatable peak torque					
Dynamic load factor C [N]	21800					
Static load factor C <sub>0</sub> [N]	35800					

\* Values for half-step operation

## Dimensioned drawings

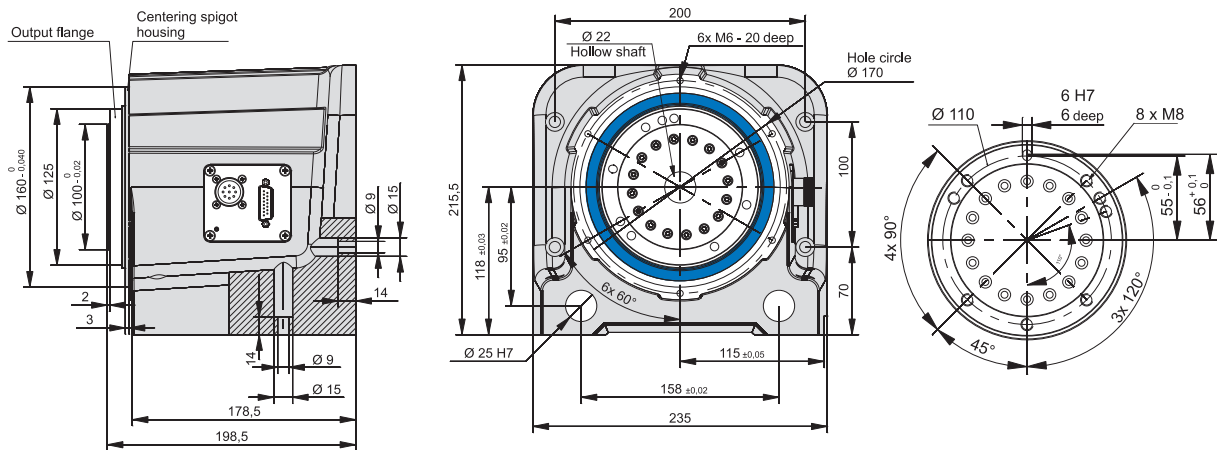

Versions	Part no.	L	A
Tailstock unit RE-M 1000 mm	269100 2100	1110	624,5
Tailstock unit RE-M 1500 mm	269100 2150	1610	1124,5
Tailstock unit RE-M 2000 mm	269100 2200	2110	1624,5

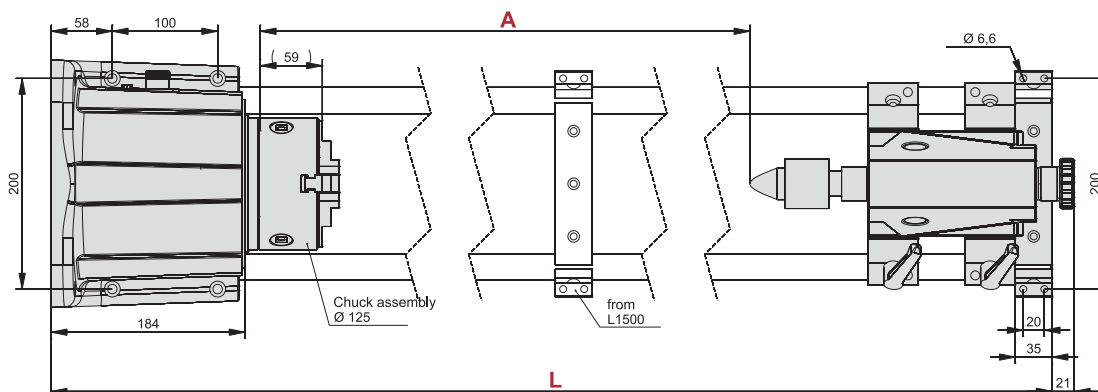

## Indexing table / Rotary unit

## RDH-S

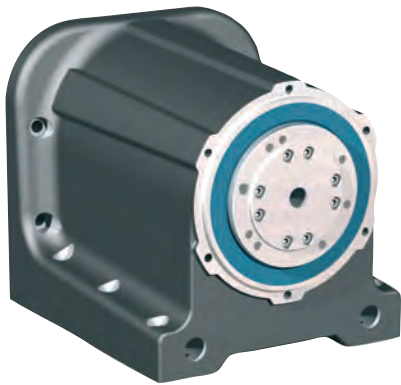

RDH-S as indexing table  
(solid shaft design)

RDH-S as rotary unit  
(hollow shaft design)



## Features

- With precision transmission
  - High load capacity, rigid drive bearing
  - Absence of play and high torsional rigidity
- Reduction 1:51 or 1:101
- Stepper or servomotor
- Protection class IP 65
- Stainless design
- Transfer accuracy < 1.5 minute of arc
- Repeatability <  $\pm 6$  seconds of arc
- Available in solid or hollow shaft design
- No maintenance

For pin assignment see page C122  
For transport loads, see page C123

## Ordering key

2 6 6 1 X X 0 X 0 0

## Flanged shaft

0 = solid shaft  
1 = hollow shaft

## Transmission reduction

0 = 101  
1 = 51

## Motors

0 = Stepper motor MS 045 HT with encoder (400 imp., 3-channel, RS422)  
2 = brushless DC servomotor RE 40  
3 = brushless EC servomotor EC 42  
5 = Stepper motor without encoder

## Accessories



## Chuck assembly

3-jaw chuck  $\varnothing$  65

Part no.: **269060 3065\***

3-jaw chuck  $\varnothing$  80

Part no.: **269060 2080\***

3-jaw chuck  $\varnothing$  100

Part no.: **269060 2100\***



## Chuck jaws

4-jaw chuck  $\varnothing$  100

Part no.: **269061 2100\***

\* including flange



## Tailstock unit RE S

for RDH-S

Part no.: **269100 1020** (200 mm)

Part no.: **269100 1030** (300 mm)

Part no.: **269100 1040** (400 mm)

Part no.: **269100 1050** (500 mm)

# Indexing table / Rotary unit

# RDH-S

## Technical specification

	Stepper motor MS 045 HT *		EC servomotor EC 42 (brushless)		DC servomotor RE 40 (brushed)	
Reduction ratio	1:51	1:101	1:51	1:101	1:51	1:101
Nominal speed [1/min]	4	2	22	11	22	11
	at 1500 Hz (225 1/min)		at 1100 1/min		at 1100 1/min	
Max. speed [1/min]	24	12	59	30	69	35
	at 8000 Hz		--			
Nominal torque [Nm]	7	11	4.8	9.2	4.6	9
	at 1500 Hz		--			
Max. torque (short term) [Nm]	--	--	7	11	7	11
Nominal holding torque (static load) [Nm]	7	11	7	11	7	11
Max. Transmission load [Nm]	18	28	18	28	18	28
	Limit for repeatable peak torque					
Dynamic load factor C [N]	5800					
Static load factor C <sub>0</sub> [N]	8600					

\* Values at half-step operation

## Dimensioned drawings

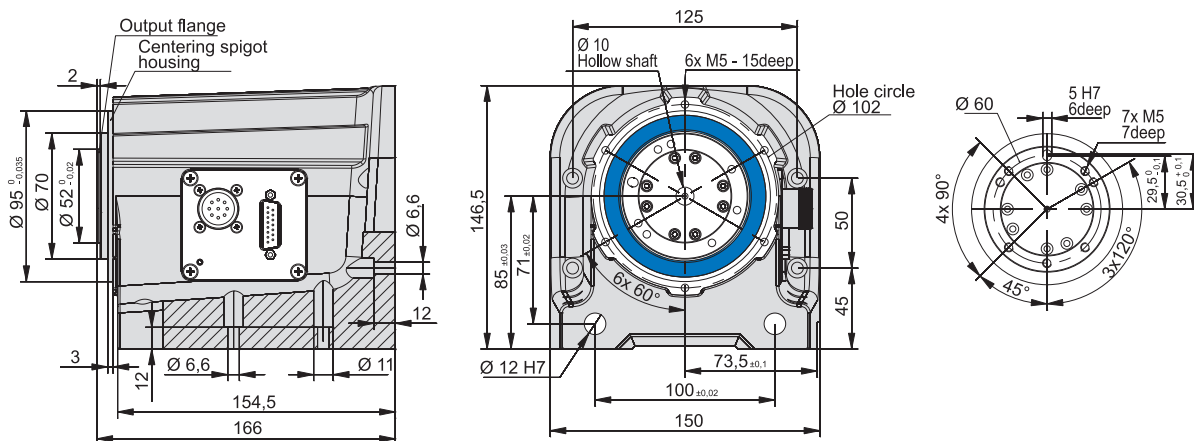

Versions	Part-no.	L	A
Tailstock unit RE-S 200 mm	269100 1020	370	128
Tailstock unit RE-S 300 mm	269100 1030	470	228
Tailstock unit RE-S 400 mm	269100 1040	570	328
Tailstock unit RE-S 500 mm	269100 1050	670	428

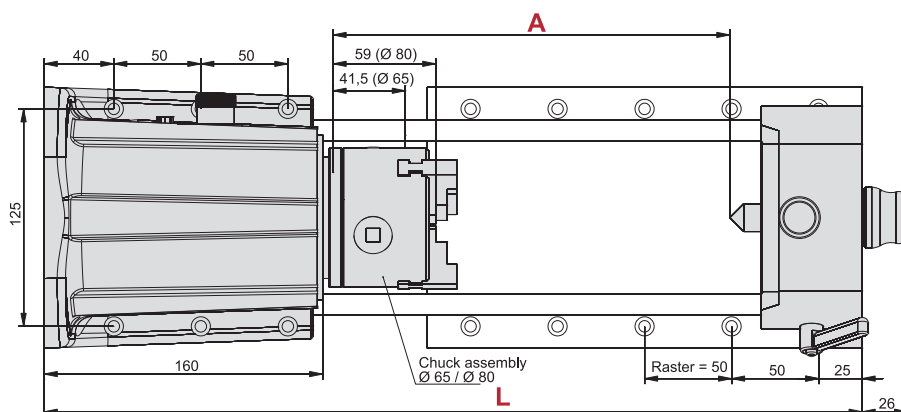

## Indexing table / Rotary unit

## RDH-XS



RDH-XS as rotary unit

RDH-XS as indexing table



## Features

- With precision transmission
  - High load capacity, rigid drive bearing
  - Absence of play and high torsional rigidity
- Reduction 1:50 or 1:100
- Stepper or servomotor
- Protection class IP 65
- Stainless design
- Transfer accuracy <math>< 2</math> minutes of arc
- Repeatability <math>< \pm 1</math> minute of arc
- No maintenance

For pin assignment see page C122  
For transport loads, see page C123

## Ordering key

2 6 0 0 X 0 X 0 0

## Transmission reduction

0 = 100

1 = 50

## Motors

0 = Stepper motor MS 045 HT with encoder (400 imp., 3-channel, RS422)

2 = brushed DC servomotor RE 40

3 = brushless EC servomotor EC 42

5 = Stepper motor without encoder

## Accessories

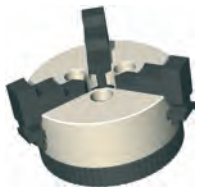

## Chuck assembly

3-jaw chuck  $\varnothing$  65Part no.: **269060 4065\***

\* including flange



## Tailstock unit RE XS

for RDH-XS

Part no.: **269100 0020** (200 mm)Part no.: **269100 0030** (300 mm)Part no.: **269100 0040** (400 mm)Part no.: **269100 0050** (500 mm)

# Indexing table / Rotary unit

# RDH-XS

## Technical specification

	Stepper motor MS 045 HT *		EC servomotor EC 42		DC servomotor RE 40	
	1:50	1:100	1:50	1:100	1:50	1:100
Reduction ratio	1:50	1:100	1:50	1:100	1:50	1:100
Nominal speed [1/min]	5	2	22	11	22	11
	at 1500 Hz (225 1/min)		at 1100 1/min		at 1100 1/min	
Max. speed [1/min]	24	12	59	30	70	35
	at 8000 Hz (1200 1/min)		--			
Nominal torque [Nm]	5	7	5	7	5	7
	at 1500 Hz (225 1/min)		--			
Max. torque (short term) [Nm]	--	--	5	7	5	7
Nominal holding torque (static load) [Nm]	5	7	5	7	5	7
Max. Transmission load [Nm]	9	14	9	14	9	14
	Limit for repeatable peak torque					
Dynamic load C [N]	392					
Static load C <sub>0</sub> [N]	392					

\* Values for half-step operation

## Dimensioned drawings

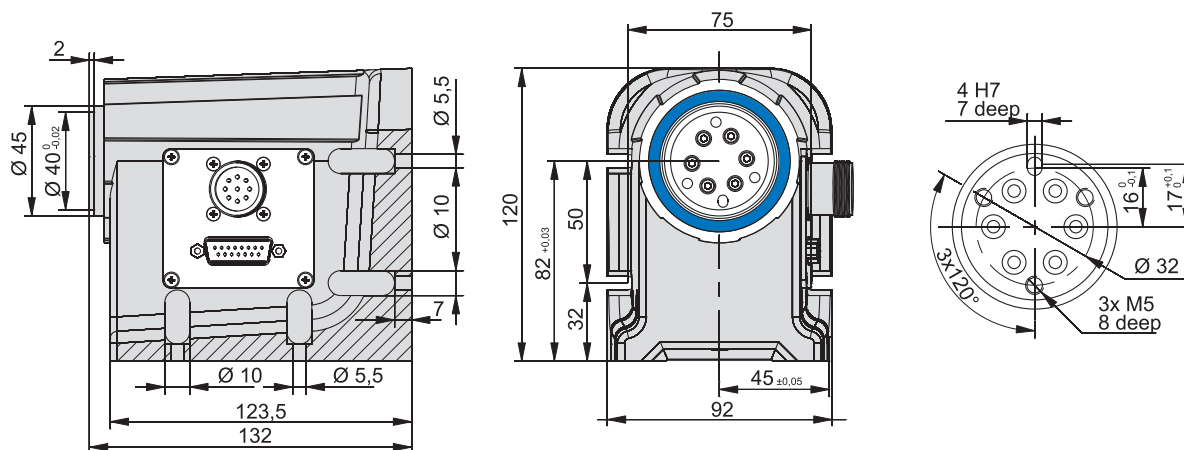

Versions	Part no.	L	A
Tailstock unit RE-XS 200 mm	269100 0020	325	117
Tailstock unit RE-XS 300 mm	269100 0030	425	217
Tailstock unit RE-XS 400 mm	269100 0040	525	317
Tailstock unit RE-XS 500 mm	269100 0050	625	417

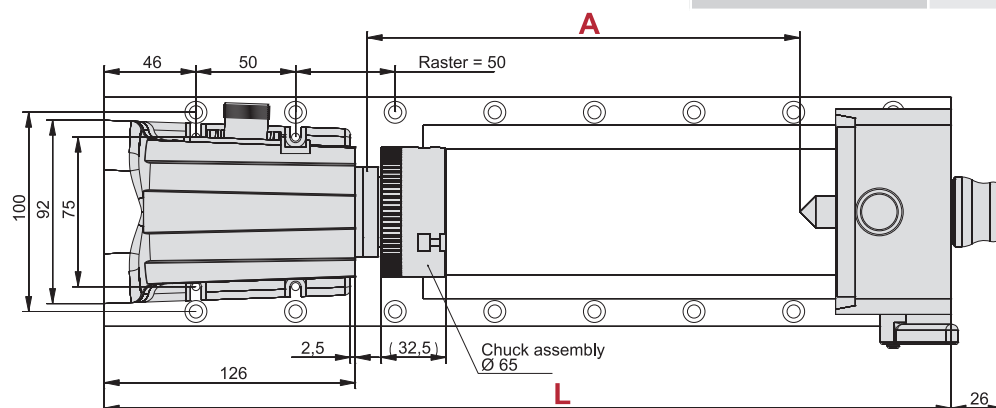

# Rotary / swivel unit

## DSH-S



### Features

- With precision transmission
  - High load capacity, rigid drive bearing
  - Absence of play and high torsional rigidity
- With rotary unit RDH-S
- Reduction 1:51 or 1:101
- Stepper or servomotor
- Protection class IP 65
- Stainless design
- Transfer accuracy < 1.5 minute of arc
- Repeatability <  $\pm 6$  seconds of arc
- No maintenance
- Swivel range continuously variable

For pin assignment see page C122  
For transport loads, see page C123

### Ordering key

2 6 5 4 1 X X 0 0 0

#### Motors

- 0 = Stepper motor MS 045 HT with encoder (400 imp., 3-channel, RS422)
- 2 = brushed DC servomotor RE 40
- 3 = brushless EC servomotor EC 42
- 5 = Stepper motor without encoder

#### Transmission reduction

- 0 = 1 : 101
- 1 = 1 : 51

### Accessories



**Chuck assembly**  
3-jaw chuck  $\varnothing$  65  
Part no.: **269060 3065\***

3-jaw chuck  $\varnothing$  80  
Part no.: **269060 2080\***

3-jaw chuck  $\varnothing$  100  
Part no.: **269060 2100\***



**Chuck assembly**  
4-jaw chuck  $\varnothing$  100  
Part no.: **269061 2100\***

\* including flange



**Circular plate**  
 $\varnothing$  150  
Part no.: **269 050 0150**

# Rotary / swivel unit

# DSH-S

## Technical specification

	Stepper motor MS 045 HT *		EC servomotor EC 42		DC servomotor RE 40	
	1:51	1:101	1:51	1:101	1:51	1:101
Reduction ratio	1:51	1:101	1:51	1:101	1:51	1:101
Nominal speed [1/min]	4	2	22	11	22	11
	at 1500 Hz (225 1/min)		at 1100 1/min		at 1100 1/min	
Max. speed [1/min]	24	12	59	30	69	35
	at 8000 Hz		--		--	
Nominal torque [Nm]	7	11	4.8	9.2	4.6	9
	at 1500 Hz		--		--	
Max. torque (short term) [Nm]	--	--	7	11	7	11
Nominal holding torque (static load) [Nm]	7	11	7	11	7	11
Max. transmission load [Nm]	18	28	18	28	18	28
	Limit for repeatable peak torque					
Dynamic load factor C [N]	5800					
Static load factor C <sub>0</sub> [N]	8600					

\* Values for half-step operation

## Dimensioned drawings

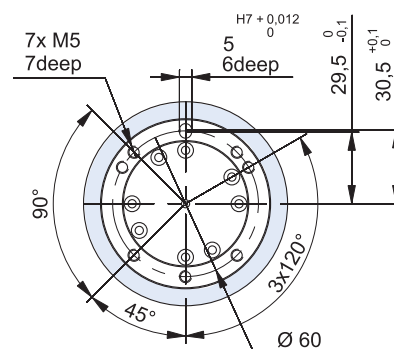
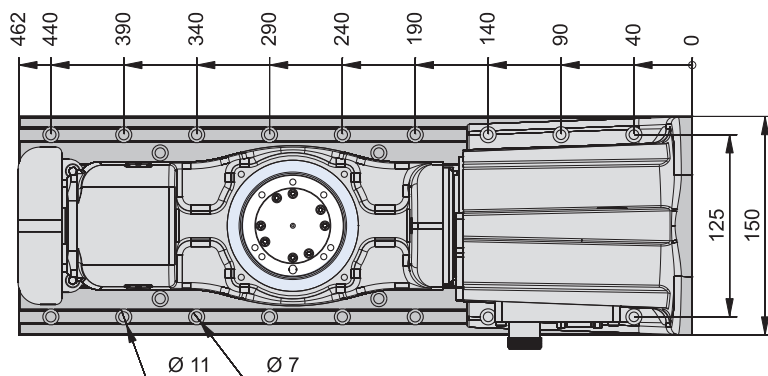
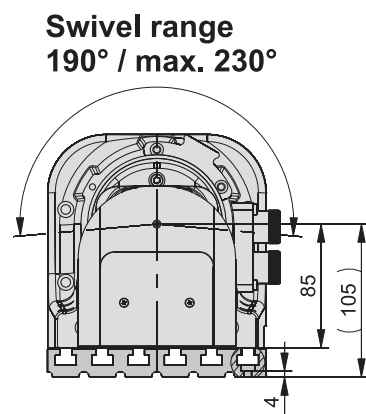
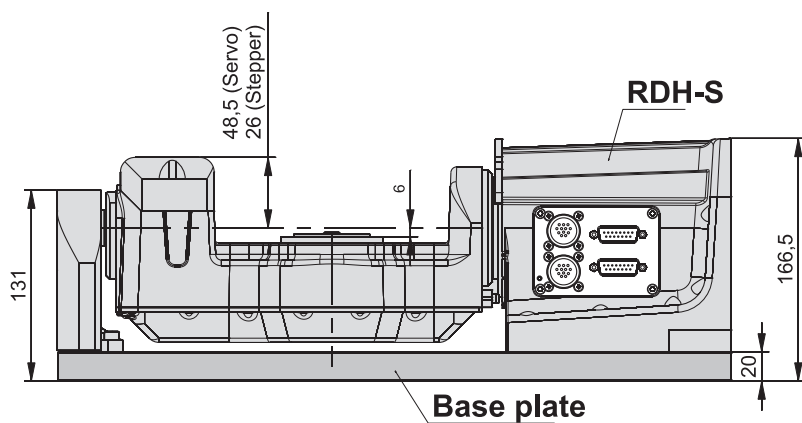

## Indexing table

## RF 1

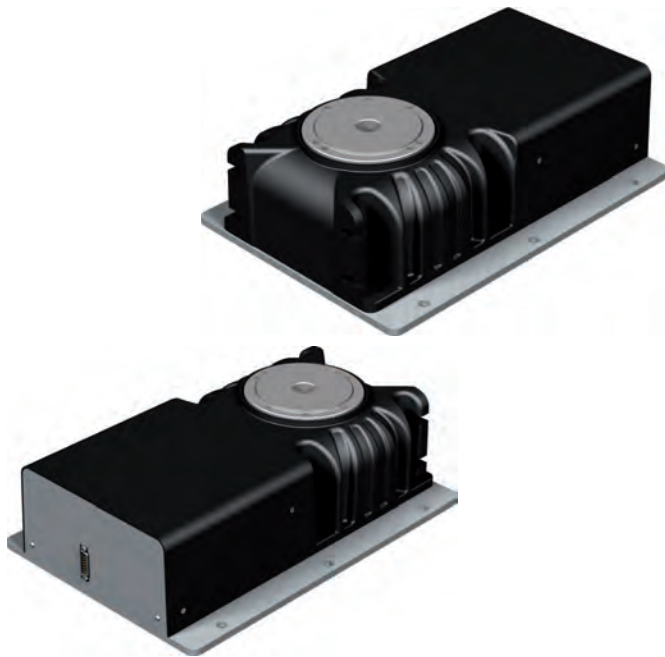

## Features

- Low play toothed belt drive with stepper or DC servo motor
- Reduction 1: 24 (standard)
- Weight: 14.6 kg

For pin assignment see page C122  
For transport loads, see page C123

## Options:

- Reduction installation set  
1 : 52 or 1 : 100
- Electromagnetic brake [60 Nm]
- Step motor drive with encoder
- CNC controller

## Ordering key

2 6 0 2 4 X X X 0 0

## Motores

- 1 = Stepper motor MS 200 HT without encoder
- 4 = brushed DC servomotor DC 100
- 5 = brushless EC servomotor EC 60S

## Brake

- 0 = without brake
- 1 = magnetic brake

## Plug

- 1 = servomotor: M23 + SubD15
- 2 = Stepper motor: SubD9

## Accessories



## Installation set

for reduction 1:52

Part no.: **269077 0001**

f for reduction 1:100

Part no.: **269077 0002**



## Aluminium T-key plate

Ø 240 mm/PT 25

Part no.: **269050 0240**

Ø 365 mm/PT 25

Part no.: **269050 0365**



## Aluminium rotary plate

Ø 490 mm, customised fixing  
borings available at extra cost

Part no.: **269051 0500**



## Chuck assembly

3-jaw chuck Ø 125

Part no.: **269062 0125**

4-jaw chuck Ø 125

Part no.: **269061 0125**

## Indexing table

## RF 1

## Technical specification

	Stepper motor MS 200 HT *			servomotor DC 100 / EC 60S		
Reduction ratio	1:24	1:52	1:100	1:24	1:52	1:100
speed [1/min]	0-50	0-23	0-12	0-125	0-58	0-30
Operation torque (0 - 500 Hz) [Nm]	20	42	75	--		
Operation torque (500 - 1000 Hz) [Nm]	18	38	75	--		
Nominal torque [Nm]	--			6 / 10	13 / 22	25 / 42
Nominal holding torque (static load) [Nm]	37	75	75	7 / 12	16 / 26	30 / 50
Min. Step (positional accuracy) [arcmin]	2.5	2	2	2	2	2

\* Values for half-step operation

## Dimensioned drawings

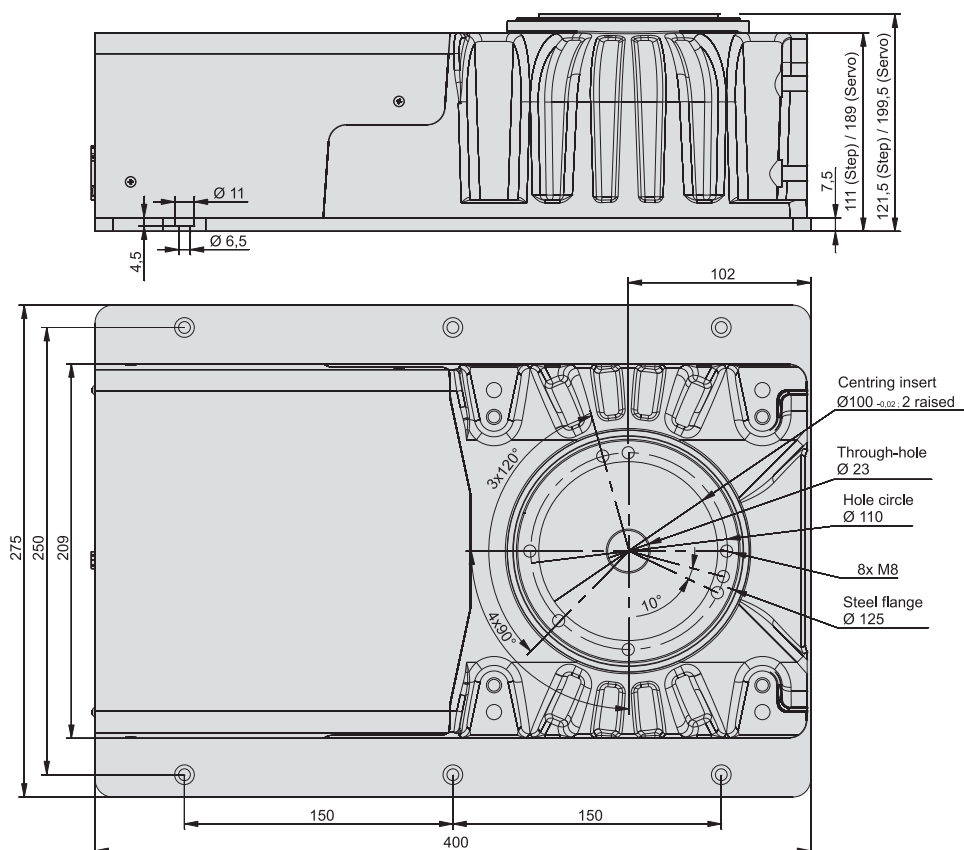

# Rotary unit

# iZD 54

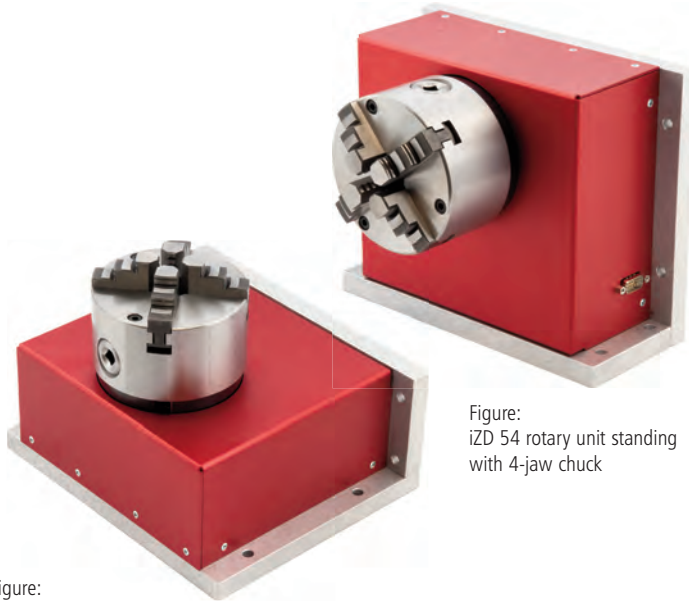

Figure:  
iZD 54 rotary unit standing  
with 4-jaw chuck

Figure:  
iZD 54 rotary unit lying  
with 4-jaw chuck

## Features

- low play toothed belt drive with stepper motor
- horizontal and vertical
- Reduction 1:54
- good price/performance ratio
- high torque
- Dimensions (L×W×H):  
220 × 185 × 95 mm
- Weight approx. 6.5 kg

For pin assignment see page C122  
For transport loads, see page C123

## Technical specification

Rotary unit iZD 54

Reduction ratio		1:54
Speed	[1/min]	0-22
Operating torque	[Nm]	30
Nominal holding torque (static load)	[Nm]	48
Min. step	[arcmin]	2

based max. 8 kHz, half-step operation

## Ordering data

Basic iZD 54 rotary unit  
Part no.: **260400 0000**

## Accessories



### Chuck assembly

3-jaw chuck Ø 100

Part no.: **269060 0100**



4-jaw chuck Ø 100

Part no.: **269061 0100**



Aluminium T-key plate Ø 250 mm, PT 24

Part no.: **269050 0250**

## Rotary unit

iZD 54

## Dimensioned drawing

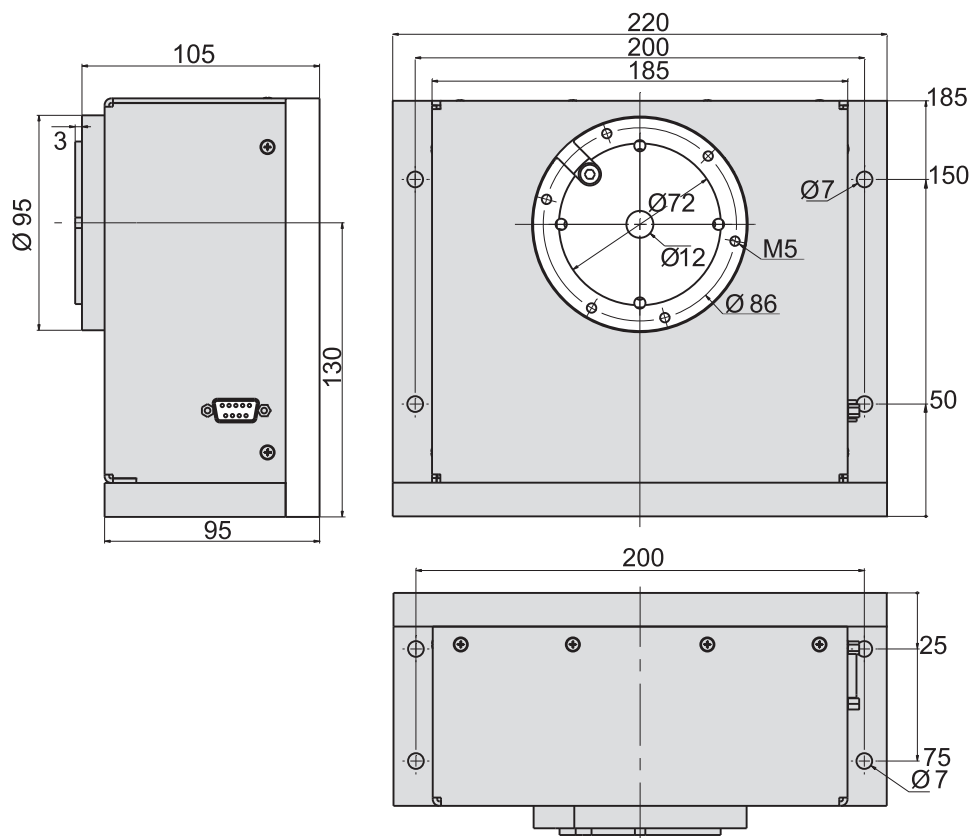

# Mini rotary unit

# MD 1

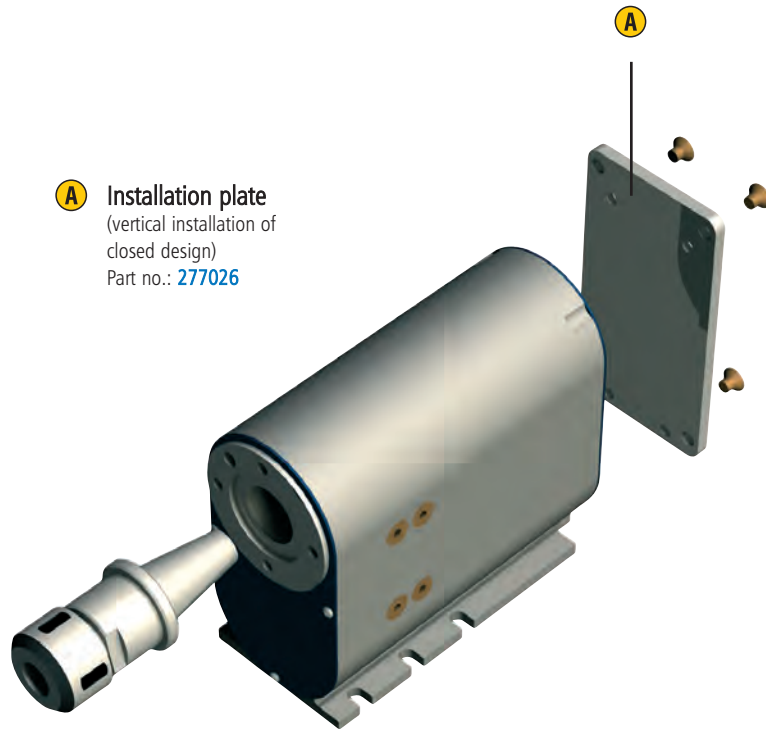

**A** Installation plate  
(vertical installation of closed design)  
Part no.: **277026**

## Features

- low play toothed belt drive with stepper or DC servo motor
- Reduction 1: 20
- Shaft with  $\varnothing$  9 mm boring
- Housing flange with inner cone SK 20
- Weight:  
according to design, from 1.35 kg

For pin assignment see page C122  
For transport loads, see page C123

### Optionen:

- additional installation plate (vertical installation possible)
- CNC controller

## Ordering key

**261010 0X10**

### Motors

- 0** = Stepper motor MS 045 HT
- 2** = brushed DC servomotor RE 40
- 3** = brushless EC servomotor EC 42

## Accessories

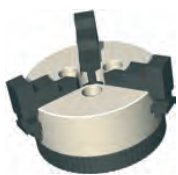

### Chuck assembly

3-jaw chuck  $\varnothing$  65  
Part no.: **269060 2065\***

\* including flange



### Collet holder

Collet holder SK 20  
for tools  $\varnothing$  3 - 10 mm, with installation ring  
Part no.: **239172 0001**

Collets are on page E 29.

# Mini rotary unit

# MD 1

## Technical specification

	Stepper motor MS 045 HT *	DC servomotor RE 40	EC servomotor EC 42
Reduction ratio	1:20	1:20	1:20
Speed [1/min]	0 - 60	0 - 175	0 - 150
Operating torque (0 - 1600 Hz) [Nm]	8	--	--
Nominal torque [Nm]	--	3	3.2
Nominal holding torque (static load) [Nm]	14	3.9	4
Min. step (positional accuracy) [arcmin]	3.5	2	2

\* Values for half-step operation

## Dimensioned drawings

	Length L for step	Length L for DC servo
closed design	129 mm	180 mm
closed with installation plate	133 mm	184 mm

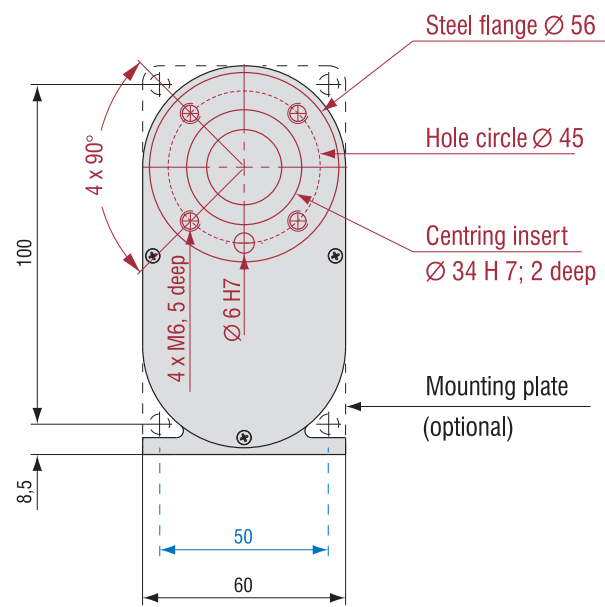
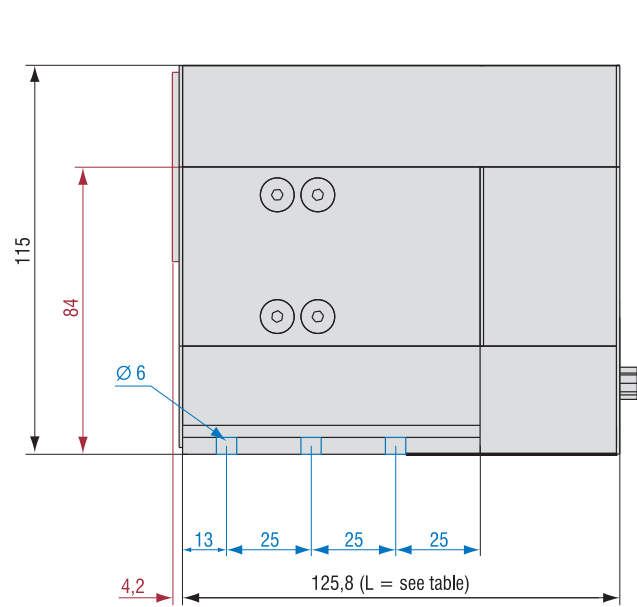
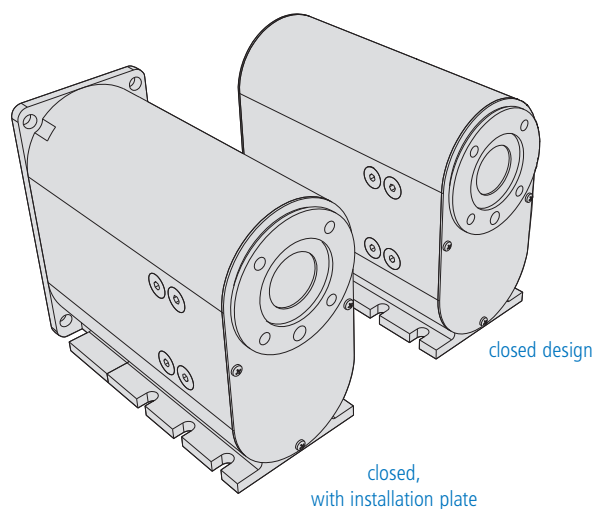

## Rotary unit

## ZD 30

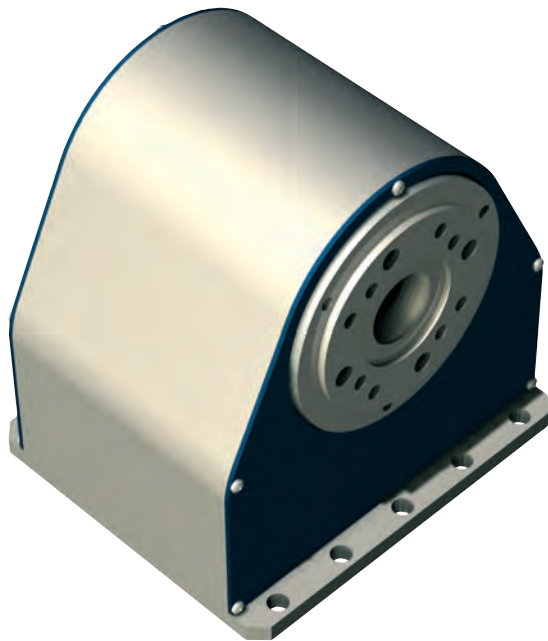

## Features

- Low play toothed belt drive with Stepper motor
- Reduction 1 : 30
- Shaft with Ø 15 mm boring
- Housing flange with inner cone SK 20
- Weight: 2,9 kg

For pin assignment see page C122  
For transport loads, see page C123

## Options:

- CNC controller via Sub D

## Ordering information

ZD 30 rotary unit  
Art.-Nr.: **261100 0000**

## Technical specification

		Stepper motor MS 045 HT *
Reduction ratio		1:30
Speed	[1/min]	0 - 40
Operating torque (0 - 1600 Hz)	[Nm]	12
Nominal holding torque (static load)	[Nm]	20
Min. step (positional accuracy)	[arcmin]	2.5

\* Values for half-step operation

## Accessories

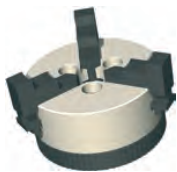

## Chuck assembly

3-jaw chuck Ø 65  
Part no.: **269060 2065\***



## Chuck assembly

3-jaw chuck Ø 80  
Part no.: **269060 3080\***



## Collet holder

Collet holder SK 20  
for tools Ø 3 - 13 mm, with  
installation ring  
Part no.: **239172 0001**

Collets are on page E 29.



## Tailstock unit RE-ZD30

200 mm Part no.: **269 100 1060** L 331  
300 mm Part no.: **269 100 1070** L 431  
400 mm Part no.: **269 100 1080** L 531  
500 mm Part no.: **269 100 1090** L 631

\* including flange

# Rotary unit

# ZD 30

## Dimensioned drawing

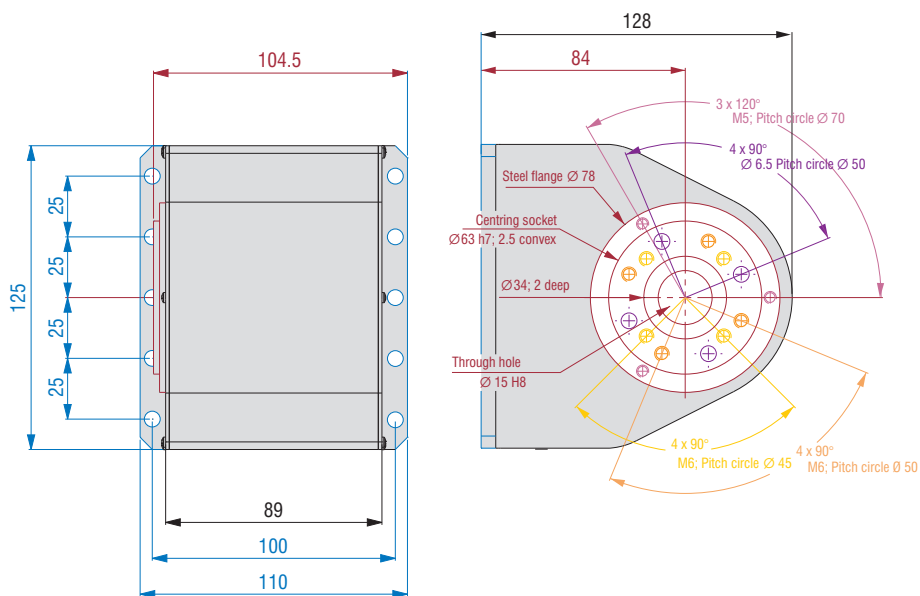

## Tailstock unit RE-ZD30

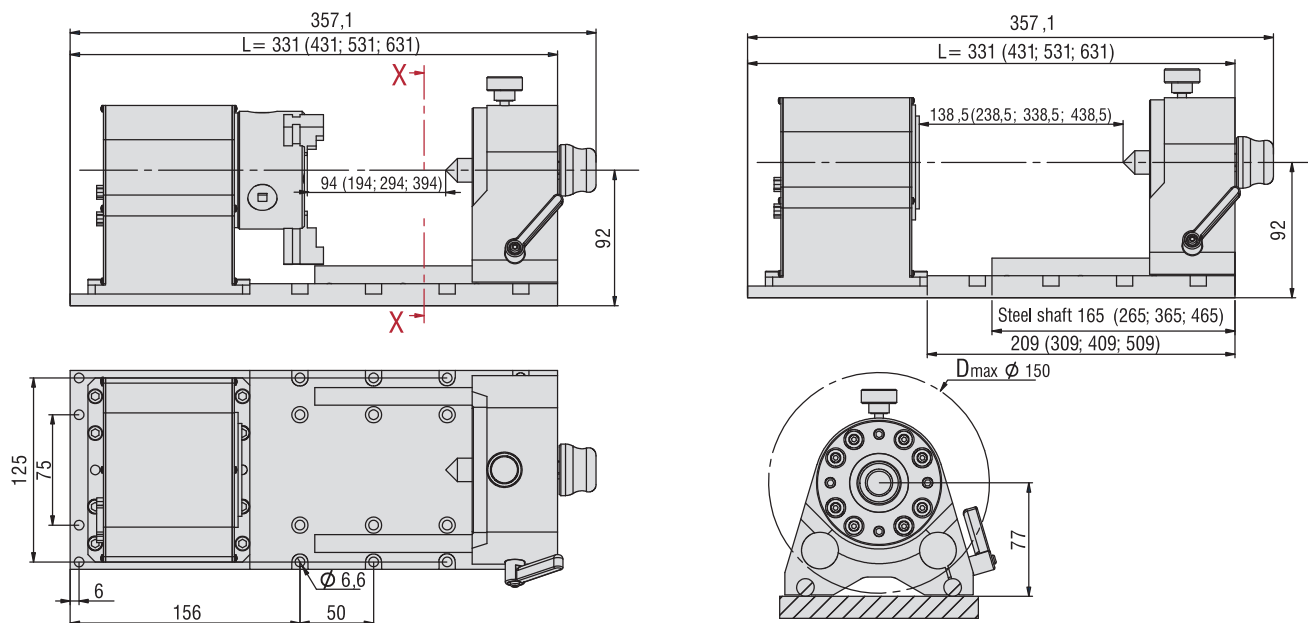

SECTIONAL DRAWING X-X

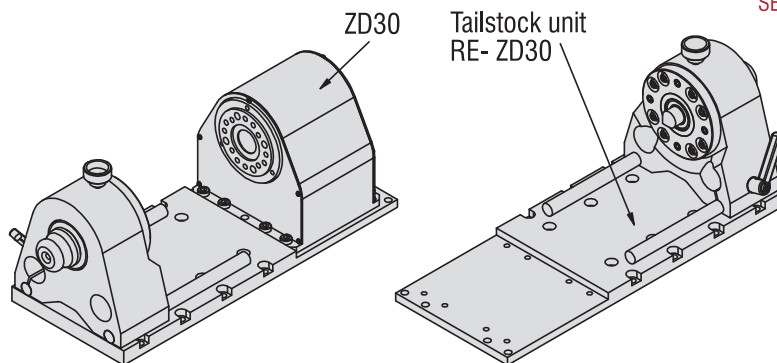

## Indexing table

## ZR 20

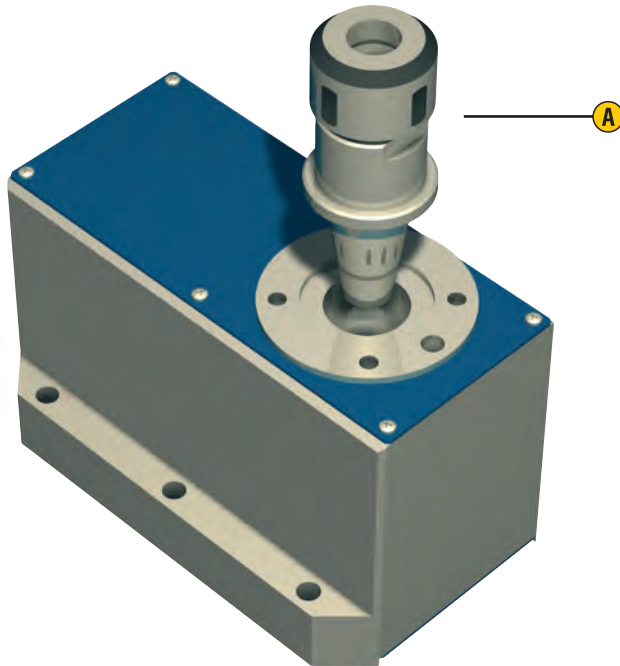

## Features

- Low play toothed belt drive with stepper motor
- Reduction 1 : 20
- Shaft with  $\varnothing$  15 mm boring
- Housing flange with inner cone SK 20•
- Weight: 2,1 kg

For pin assignment see page C122  
For transport loads, see page C123

## Options:

- CNC controller via Sub D

- A** Collet holder SK 20  
(Accessories)

## Ordering data

Indexing table ZR 20  
Part no.: **260300 0000**

## Technical specifications

		Stepper motor MS 045 HT *
Reduction ratio		1:20
Speed	[1/min]	0 - 60
Operating torque (0 - 1600 Hz)	[Nm]	8
Nominal holding torque (static load)	[Nm]	14
Min. step (positional accuracy)	[arcmin]	3.5

\* Values for half-step operation

## Accessories

see rotary / swivel unit

## Dimensioned drawing

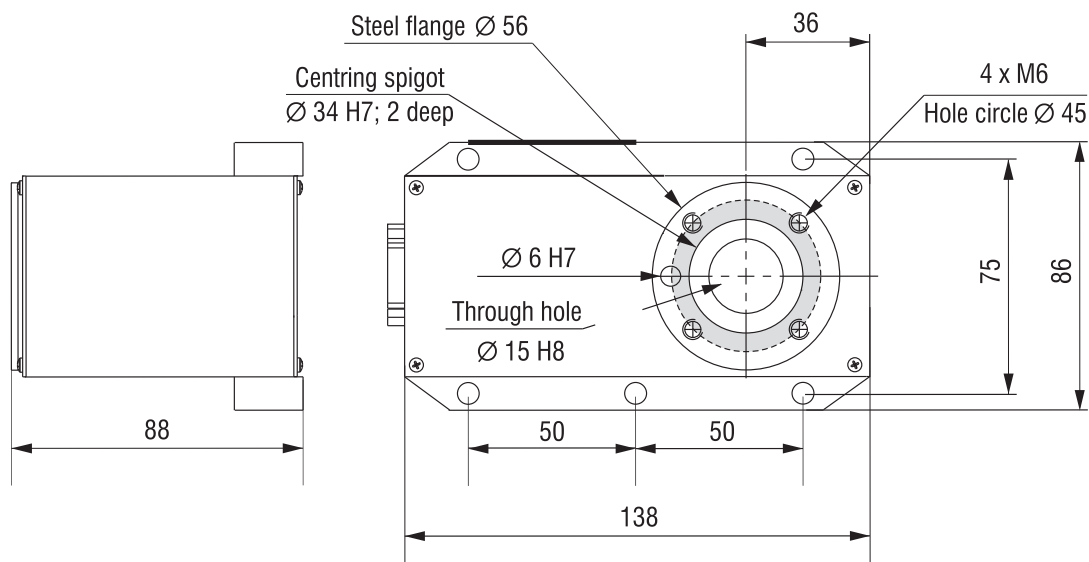

## Rotary / swivel unit

## ZDS 2030

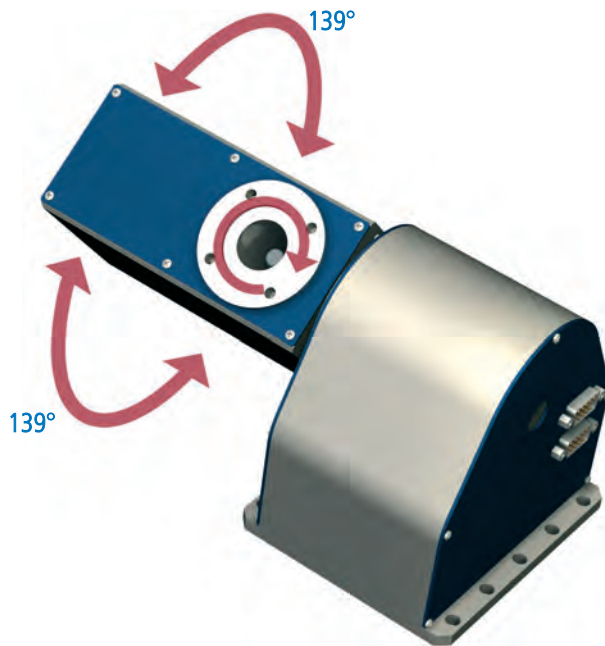

## General

The **rotary tilting unit ZDS 2030** can be used as a 4th/5th axis in CNC machines for fine workshops or in the handling area.

It is a combination of ZD 30 and the modified version of ZR 20.

ZDS 2030 enables 5-side machining or free-form surface machining on a conventional 3-axis system of easily machinable materials (e.g. plastic).

The tilting angle is 139° in both directions.

## Ordering data

Rotary / swivel unit ZDS 2030  
Part no.: **265000 0000**

## Accessories

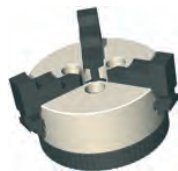

## Chuck assembly

3-jaw chuck Ø 65

Part no.: **269060 2065\***

\* including flange



## Collet holder

SK 20 collet holder for tools Ø 3 - 13 mm, with installation ring

Part no.: **239172 0001**

Collets are on page E 29.

## Dimensioned drawing

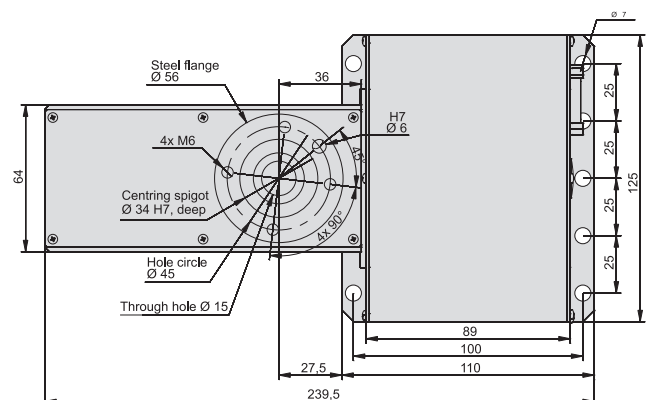
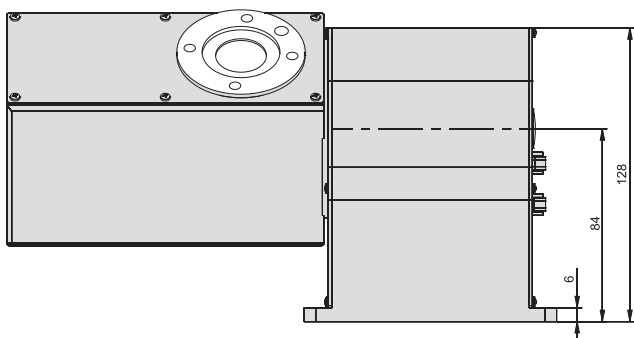

# Motor pin assignments

## Pin assignment for 12-pin stepper motors

(for RDH, DSH-S)

Motor connection

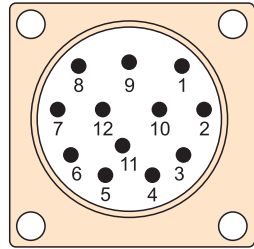

View of pin insert at the insertion side

M23 12-pin Pin	
1	Motor phase 1A
2	Motor phase 1B
3	Motor phase 2A
4	Motor phase 2B
5	+24V switch
6	+24V brake
7	GND switch
8	GND brake
9	Limit switch 1
10	Limit switch 2
11	---
12	---
Housing – cable shield	

## Pin assignment for 9-pin stepper motors

(for RF1, iZD 54, MD 1, ZD 30, ZR 20, ZDS 2030)

Motor connection

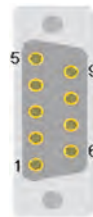

View of pin insert at the insertion side

Sub-D 9-pin Pin	
1	Motor phase 1A
2	Motor phase 1B
3	Motor phase 2A
4	Motor phase 2B
5	+24V switch
6	+24V brake
7	Limit switch 2
8	GND brake
9	Limit switch 1
Housing – cable shield	

## Pin assignment for stepper motors with encoder

(for RDH)

Motor connection

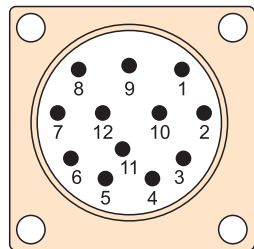

View of pin insert at the insertion side

M23 12-pin Pin	
1	Motor phase 1A
2	Motor phase 1B
3	Motor phase 2A
4	Motor phase 2B
5	+24V switch
6	+24V brake
7	GND switch
8	GND brake
9	Limit switch 1
10	Limit switch 2
11	---
12	---
Housing – cable shield	

Encoder connection

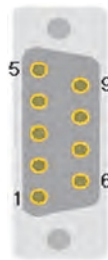

View of pin insert at the insertion side

Sub-D 9-pin Pin	
1	+5V encoder
2	Encoder track A
3	Encoder track B
4	Encoder track Z
5	---
6	GND encoder
7	Encoder track /A
8	Encoder track /B
9	Encoder track /Z
Housing – cable shield	

## Pin assignment for brushed DC servo motors (BDC)

Motor connection

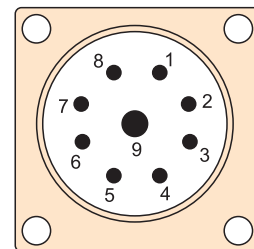

View of pin insert at the insertion side

M23 9-pin (8+1) Pin	
1	Motor phase 1 (U+)
2	Motor phase 1 (U-)
3	Motor phase 1 (U+)*
4	Motor phase 1 (U-)*
5	+24V brake
6	GND brake
7	---
8	---
9	Earthing lead
Housing – cable shield	

\* Motor phases are connected partially over 2 wires.

Encoder connection

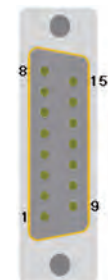

View of pin insert at the insertion side

Sub-D 15-pin Pin	
1	---
2	+5V encoder
3	Encoder track /Z
4	Encoder track /B
5	Encoder track /A
6	+24V switch
7	Limit switch 1
8	GND switch
9	---
10	GND encoder
11	Encoder track Z
12	Encoder track B
13	Encoder track A
14	Reference switch
15	Limit switch 2
Housing – cable shield	

## Pin assignment for brushless EC servo motors (BLDC)

Motor connection

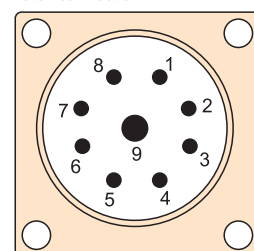

View of pin insert at the insertion side

M23 9-pin (8+1) Pin	
1	Motor phase U
2	Motor phase V
3	Motor phase W
4	---
5	+24V brake
6	GND brake
7	---
8	---
9	Earthing lead
Housing – cable shield	

Encoder connection

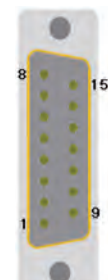

View of pin insert at the insertion side

Sub-D 15-pin Pin	
1	Hall signal A
2	+5V encoder / Hall
3	Encoder track /Z
4	Encoder track /B
5	Encoder track /A
6	+24V switch
7	Limit switch 1
8	GND switch
9	Hall signal B
10	GND encoder
11	Encoder track Z
12	Encoder track B
13	Encoder track A
14	Hall signal C
15	Limit switch 2
Housing – cable shield	

Rotary- / swivel- / Rotation units

# Transport loads, machining forces, feed

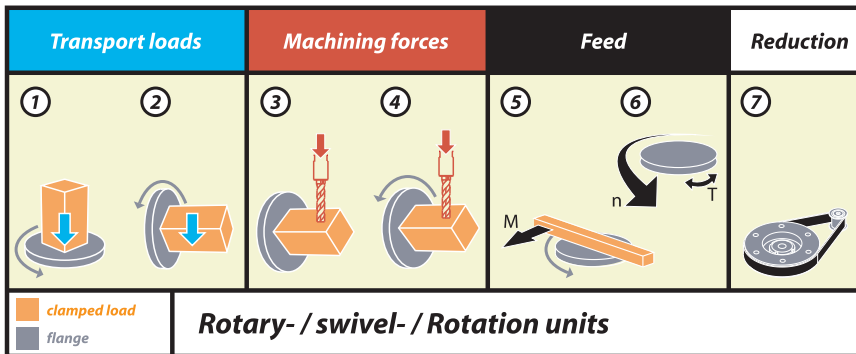

Rotary or Swivel units	1*	2*	3	4	5	6	7
RDH-M (step)	100 kg	45 kg	55 Nm	24 Nm	24 Nm	4 1/min.	1:51
RDH-M (step)	160 kg	70 kg	108 Nm	45 Nm	45 Nm	2 1/min.	1:101
RDH-M (brushless EC-servo)	110 kg	50 kg	26 Nm	9 Nm	9 Nm	22 1/min.	1:51
RDH-M (brushless EC-servo)	180 kg	80 kg	51 Nm	17 Nm	17 Nm	11 1/min.	1:101
RDH-S (Step)	30 kg	15 kg	7 Nm	7 Nm	7 Nm	4 1/min.	1:51
RDH-S (Step)	48 kg	24 kg	11 Nm	11 Nm	11 Nm	2 1/min.	1:101
RDH-S (brushless EC-servo)	30 kg	15 kg	7 Nm	4.6 Nm	4.6 Nm	22 1/min.	1:51
RDH-S (brushless EC-servo)	48 kg	24 kg	11 Nm	4.6 Nm	9.2 Nm	11 1/min.	1:101
RDH-S (DC-Servo)	25 kg	13 kg	7 Nm	4.6 Nm	4.6 Nm	22 1/min.	1:51
RDH-S (DC-Servo)	40 kg	20 kg	11 Nm	8.7 Nm	8.7 Nm	11 1/min.	1:101
RDH-XS (Step)	30 kg	10 kg	5 Nm	5 Nm	5 Nm	24 1/min.	1:50
RDH-XS (Step)	30 kg	10 kg	7 Nm	7 Nm	7 Nm	12 1/min.	1:100
RDH-XS (brushless EC-Servo)	30 kg	10 kg	5 Nm	5 Nm	5 Nm	59 1/min.	1:50
RDH-XS (brushless EC-Servo)	30 kg	10 kg	7 Nm	7 Nm	7 Nm	30 1/min.	1:100
RDH-XS (DC-Servo)	30 kg	10 kg	5 Nm	5 Nm	5 Nm	70 1/min.	1:50
RDH-XS (DC-Servo)	30 kg	10 kg	7 Nm	7 Nm	7 Nm	35 1/min.	1:100
RF 1 (Step)	60 kg	30 kg	37 Nm	17.5 Nm	17.5 Nm	50 1/min.	1:24
RF 1 (Step)	100 kg	50 kg	75 Nm	38 Nm	38 Nm	23 1/min.	1:52
RF 1 (Step)	150 kg	75 kg	75 Nm	75 Nm	75 Nm	12 1/min.	1:100
RF 1 (DC-Servo / EC Servo)	70 kg	35 kg	7 / 12 Nm	6 / 10 Nm	6 / 10 Nm	125 U/min.	1:24
RF 1 (DC servo / EC servo)	110 kg	55 kg	16 / 26 Nm	13 / 22 Nm	13 / 22 Nm	58 U/min.	1:52
RF 1 (DC servo / EC servo)	160 kg	80 kg	30 / 50 Nm	25 / 42 Nm	25 / 42 Nm	30 U/min.	1:100
MD 1 (Step)	5 kg	2,5 kg	14 Nm	8 Nm	8 Nm	60 U/min.	1:20
MD 1 (DC servo)	6 kg	3 kg	3,9 Nm	3 Nm	3 Nm	175 U/min.	1:20
MD 1 (brushless EC-servo)	6 kg	3 kg	4 Nm	3,2 Nm	3,2 Nm	150 U/min.	1:20
ZR 20 (step)	10 kg	5 kg	14 Nm	8 Nm	8 Nm	60 U/min.	1:20
ZD 30 (Step)	14 kg	8 kg	20 Nm	12 Nm	12 Nm	40 U/min.	1:30
iZD 54	30 kg	15 kg	48 Nm	30 Nm	30 Nm	22 U/min.	1:54

\*) Guideline values, which will vary according to the use.